

# Signal machines : localization of isolated accumulation

Jérôme Durand-Lose



Laboratoire d'Informatique Fondamentale d'Orléans,  
Université d'Orléans, Orléans, FRANCE



6 mars 2011 — Journées Calculabilités — Paris

- 1 Signal machines and isolated accumulations
- 2 Necessary conditions on the coordinates of isolated accumulations
- 3 Manipulating *c.e.* and *d-c.e.* real numbers
- 4 Accumulating at *c.e.* and *d-c.e.* real numbers
- 5 Conclusion

- 1 Signal machines and isolated accumulations
- 2 Necessary conditions on the coordinates of isolated accumulations
- 3 Manipulating *c.e.* and *d-c.e.* real numbers
- 4 Accumulating at *c.e.* and *d-c.e.* real numbers
- 5 Conclusion

# “Nice regular drawings”

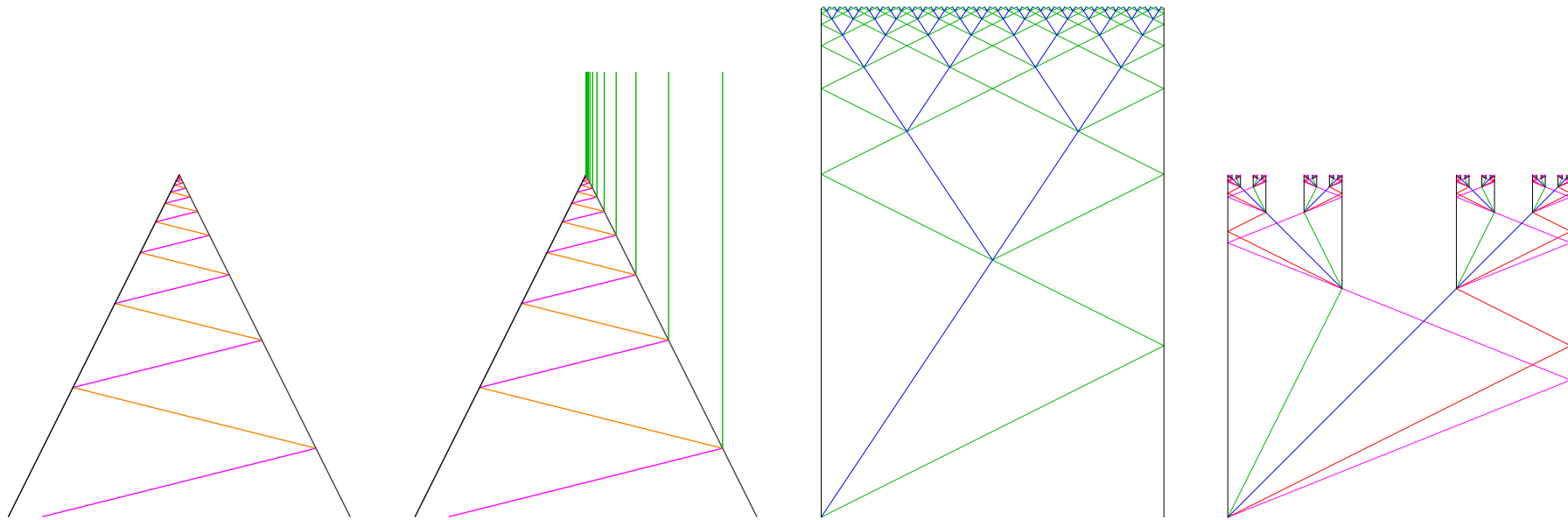

# “Nice regular drawings”

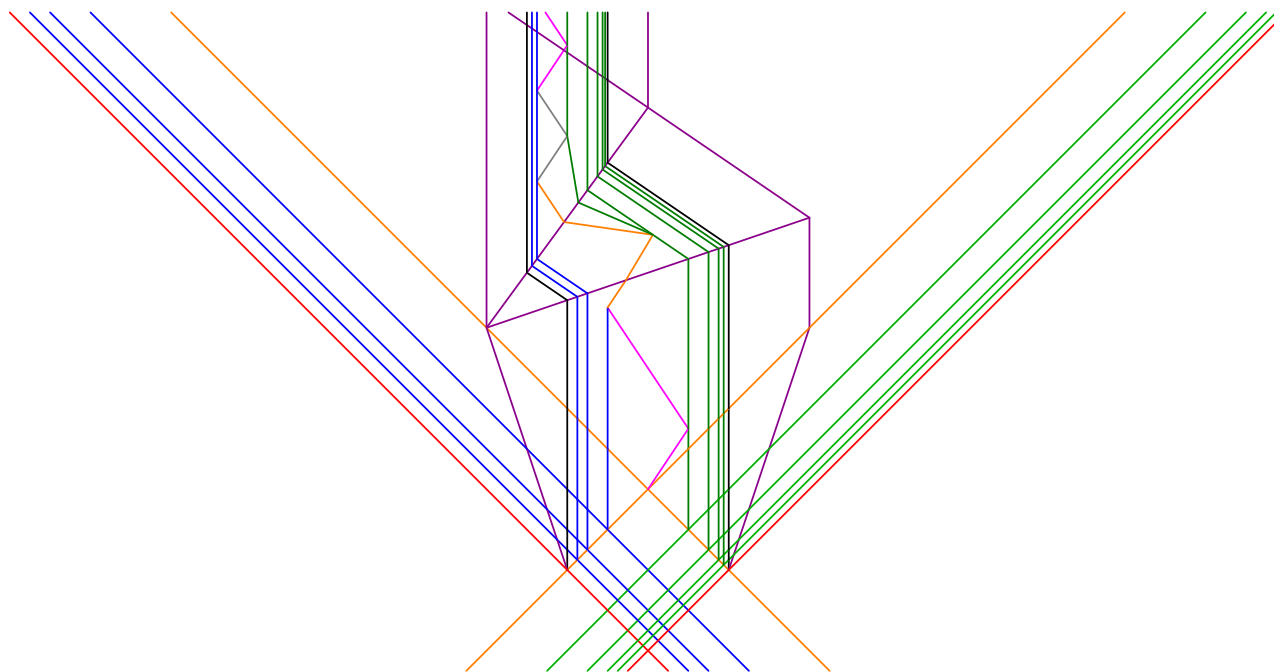

“Nice regular drawings”

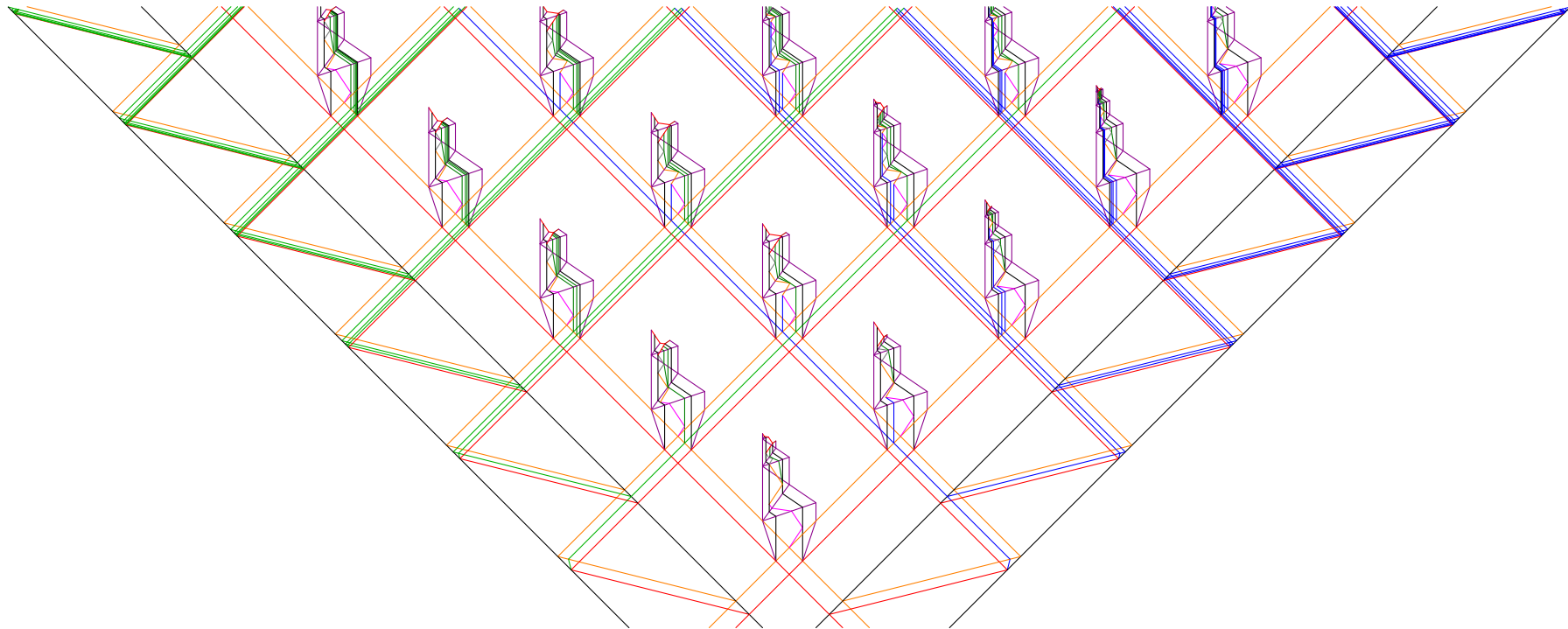

# “Nice regular drawings”

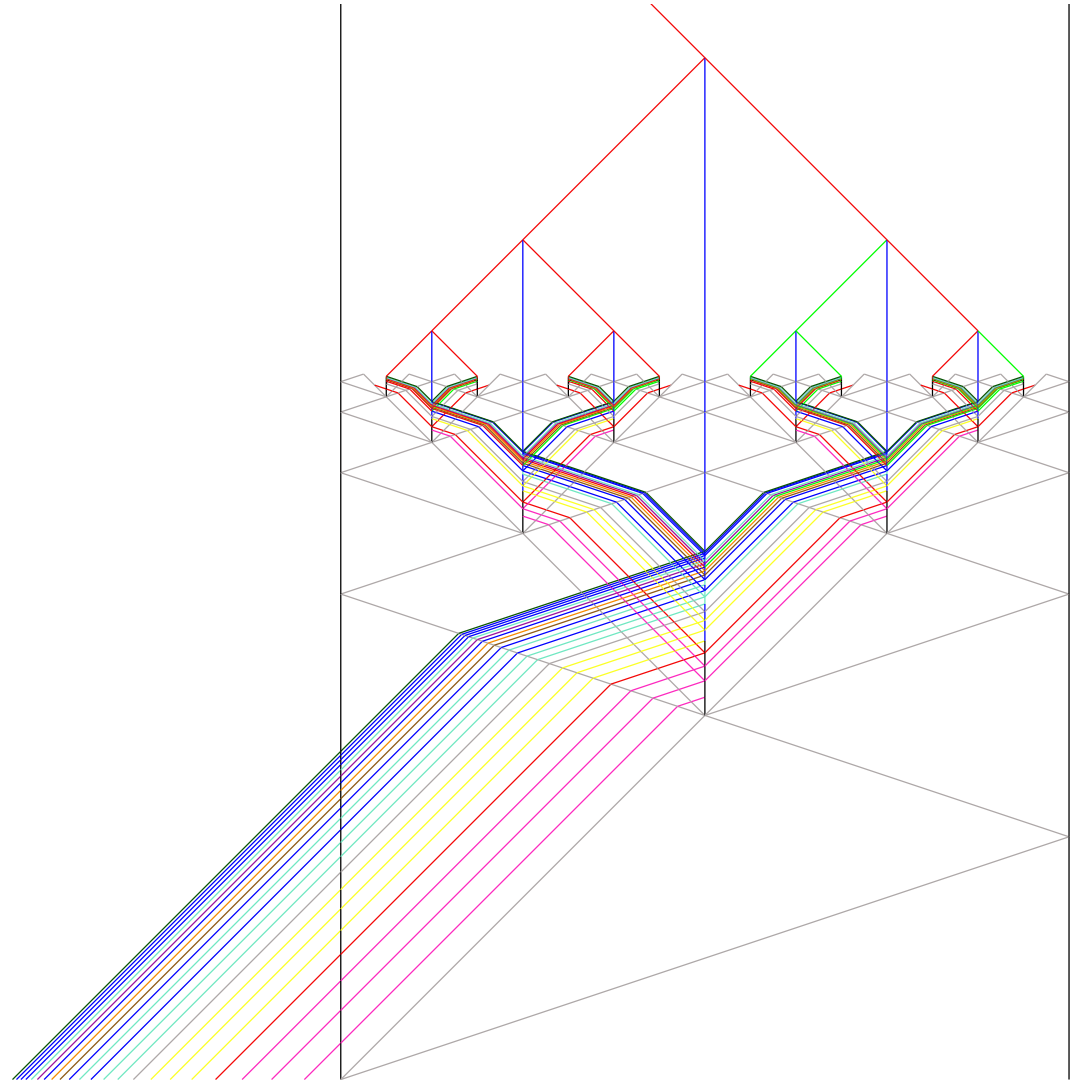

# “Nice regular drawings”

Lines: traces of signals

Space-time diagrams of signal machines

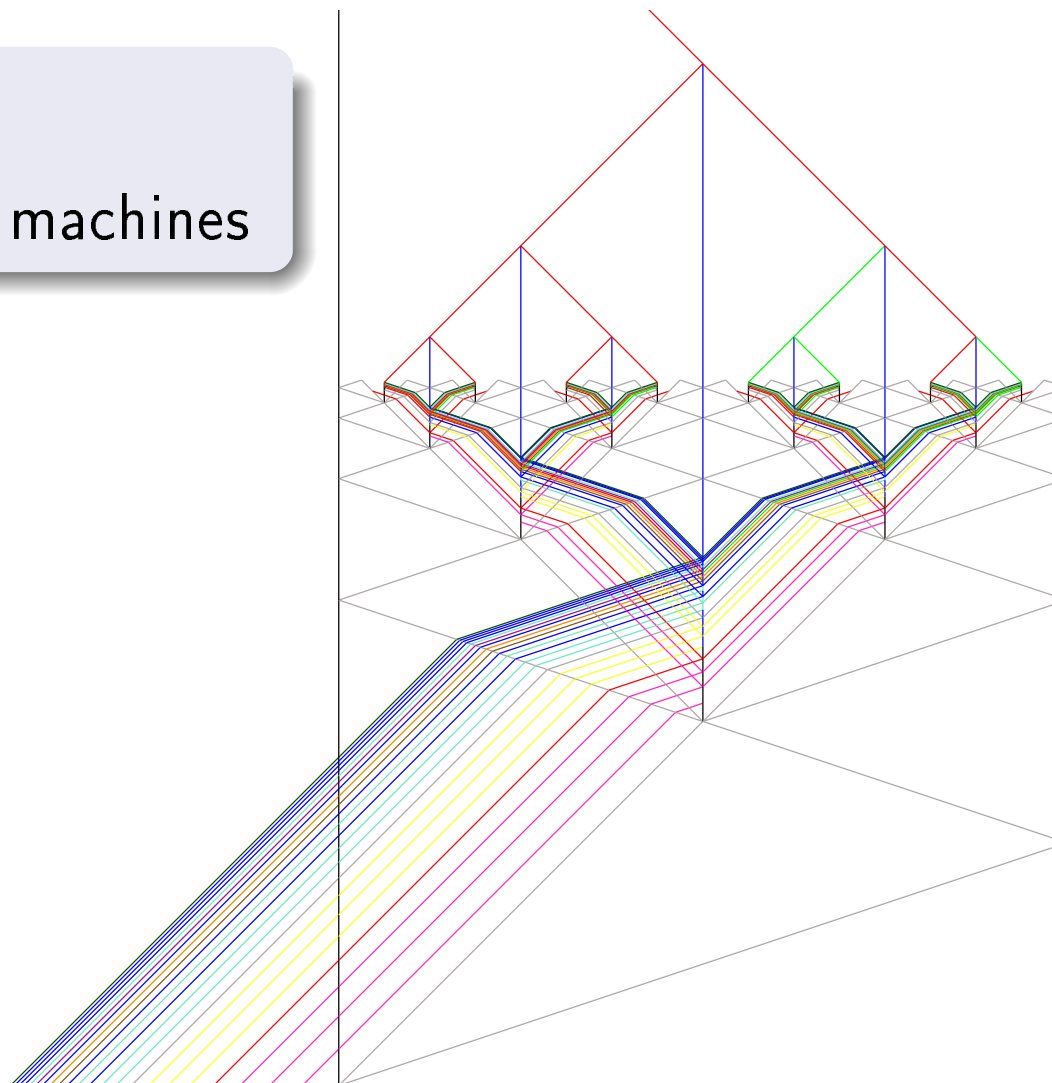



# “Nice regular drawings”

Lines: traces of signals

Space-time diagrams of signal machines

Defined by

- bottom: initial configuration
- lines: signals  $\rightsquigarrow$  meta-signals
- end-points: collisions  $\rightsquigarrow$  rules

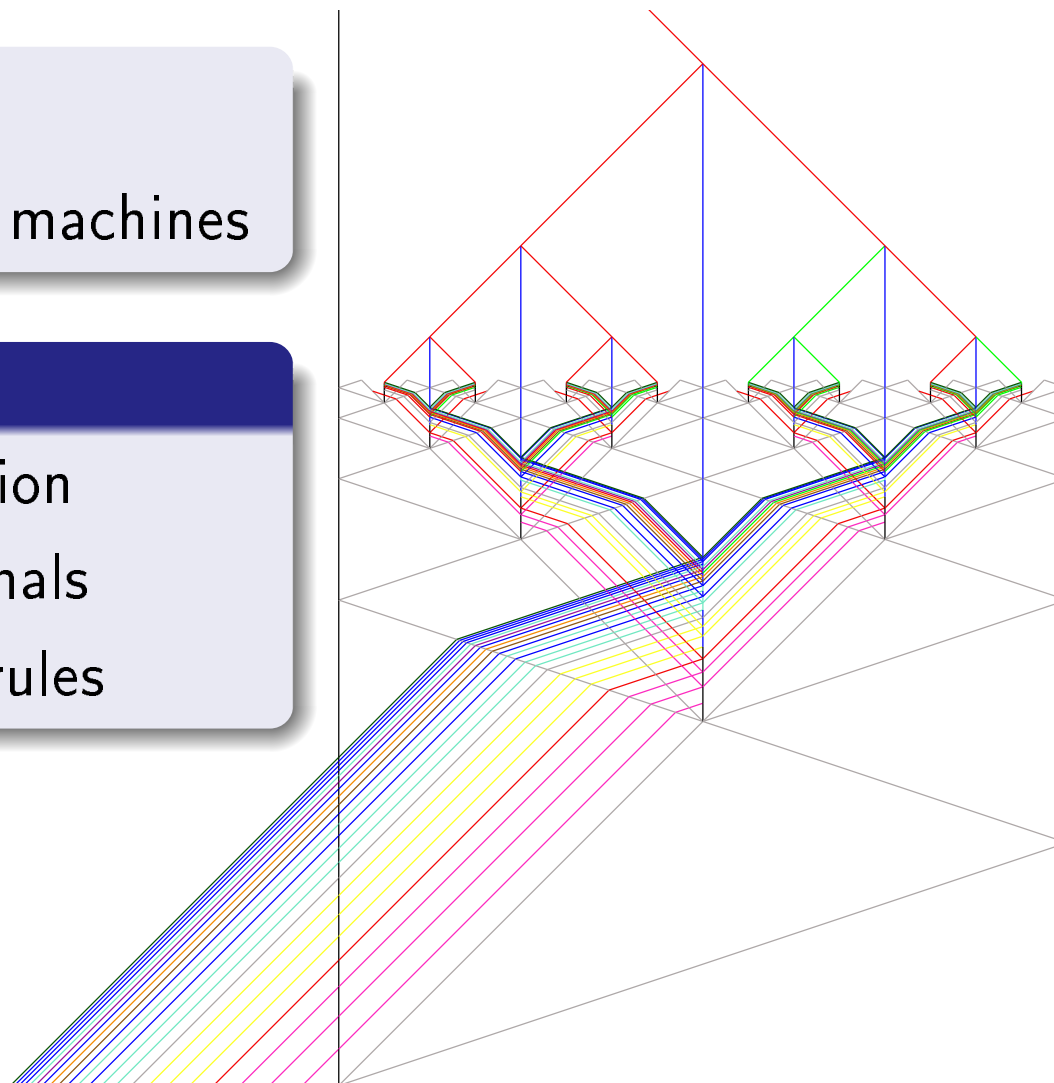

# Example: find the middle

## Meta-signals (speed)

M (0)

M |

M |

## Collision rules

# Example: find the middle



## Meta-signals (speed)

M (0)  
div (3)

## Collision rules

# Example: find the middle

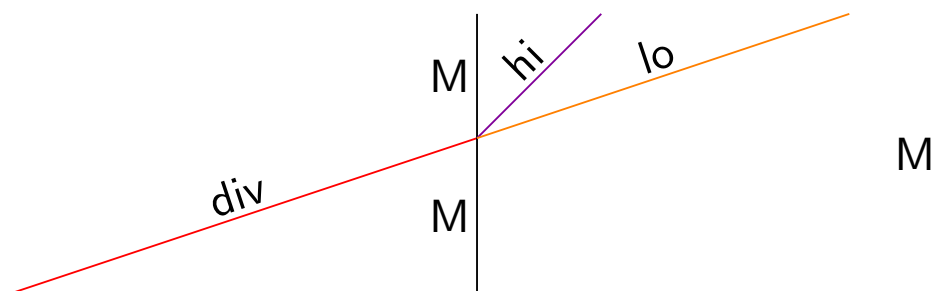

## Meta-signals (speed)

M (0)  
div (3)  
hi (1)  
lo (3)

## Collision rules

$\{ \text{div}, M \} \rightarrow \{ M, \text{hi}, \text{lo} \}$

# Example: find the middle

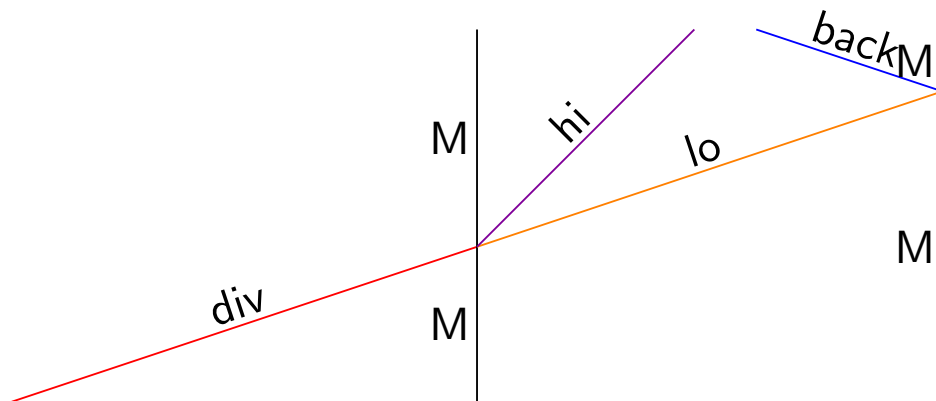

## Meta-signals (speed)

M (0)  
 div (3)  
 hi (1)  
 lo (3)  
 back (-3)

## Collision rules

$\{ \text{div}, M \} \rightarrow \{ M, \text{hi}, \text{lo} \}$   
 $\{ \text{lo}, M \} \rightarrow \{ \text{back}, M \}$

# Example: find the middle

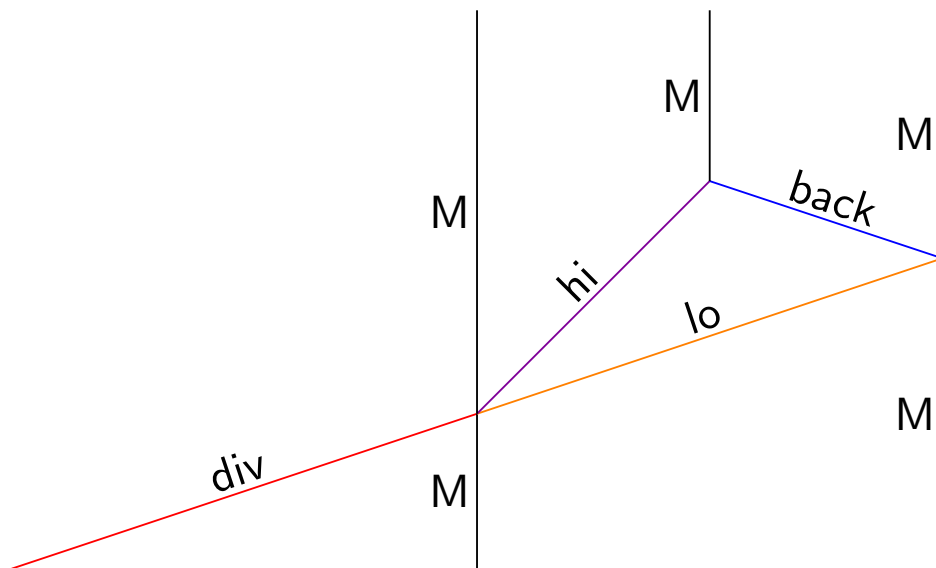

## Meta-signals (speed)

M (0)  
 div (3)  
 hi (1)  
 lo (3)  
 back (-3)

## Collision rules

$\{ \text{div}, M \} \rightarrow \{ M, \text{hi}, \text{lo} \}$   
 $\{ \text{lo}, M \} \rightarrow \{ \text{back}, M \}$   
 $\{ \text{hi}, \text{back} \} \rightarrow \{ M \}$









# Geometric primitives: accelerating and bounding time

## Normal

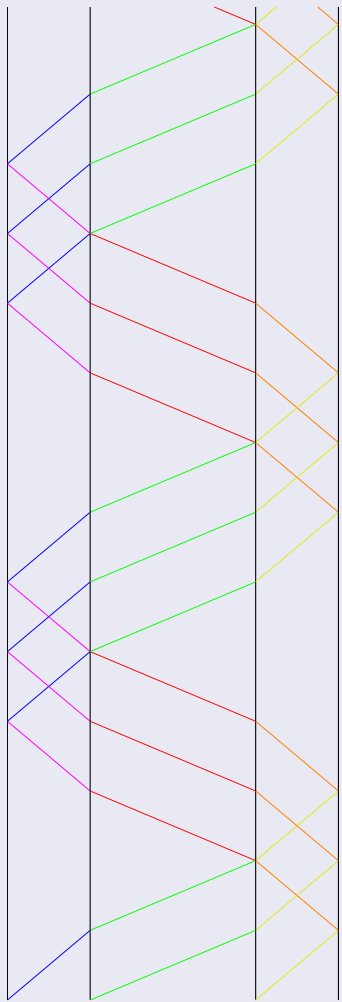

## Shrunk

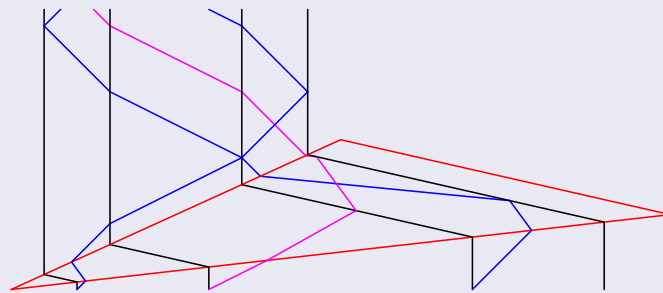

# Geometric primitives: accelerating and bounding time

Normal

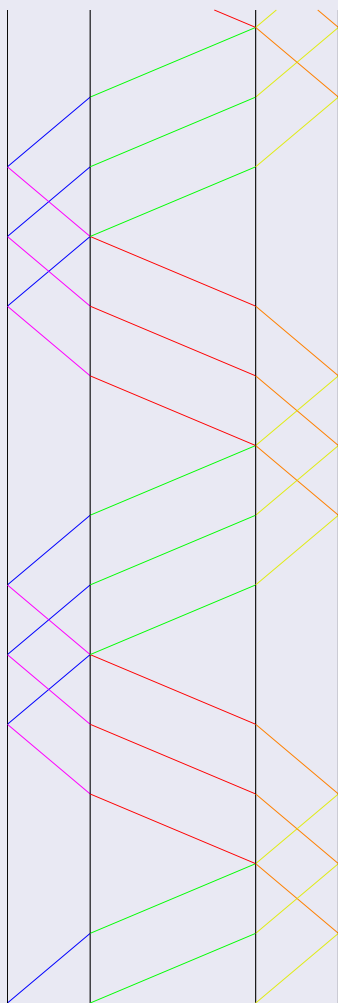

Shrunk

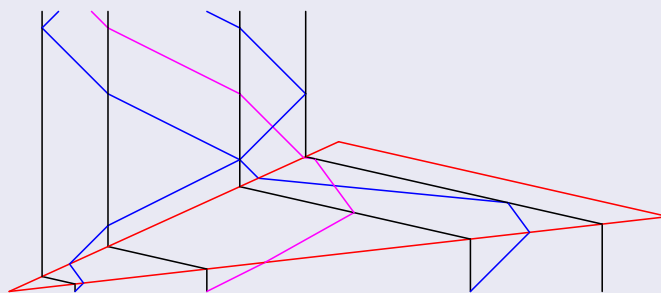

Iterated

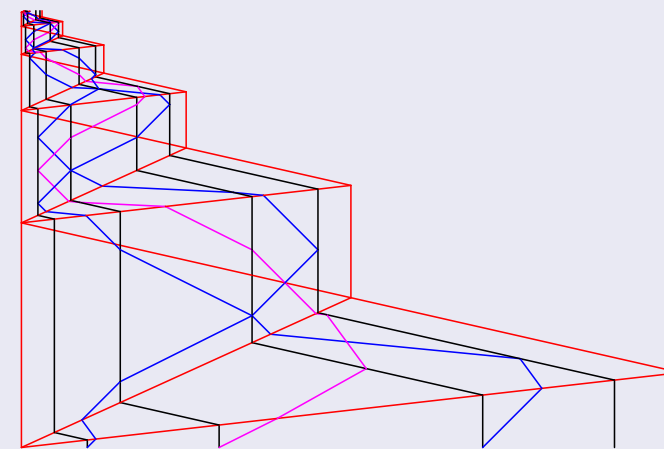

# Rational signal machines and isolated accumulations

## $\mathbb{Q}$ signal machine

- all speed are in  $\mathbb{Q}$
- all initial positions are in  $\mathbb{Q}$
- $\Rightarrow$  all location remains in  $\mathbb{Q}$

## Space and time location

- Easy to compute

## Simplest accumulation

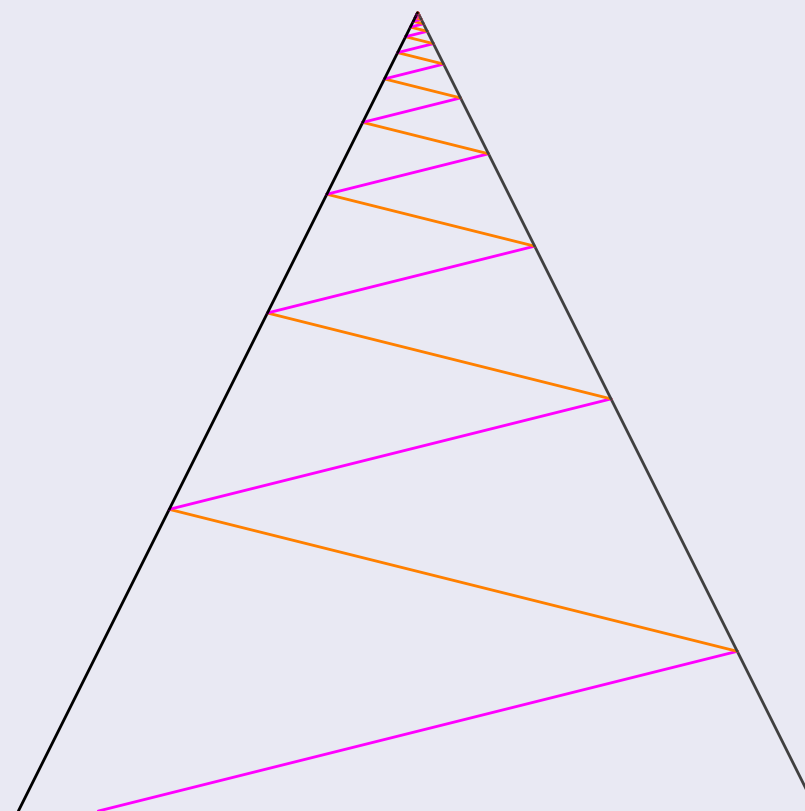

# Rational signal machines and isolated accumulations

## $\mathbb{Q}$ signal machine

- all speed are in  $\mathbb{Q}$
- all initial positions are in  $\mathbb{Q}$
- $\Rightarrow$  all location remains in  $\mathbb{Q}$

## Space and time location

- Easy to compute
- Not so easy to guess

## Accumulation?

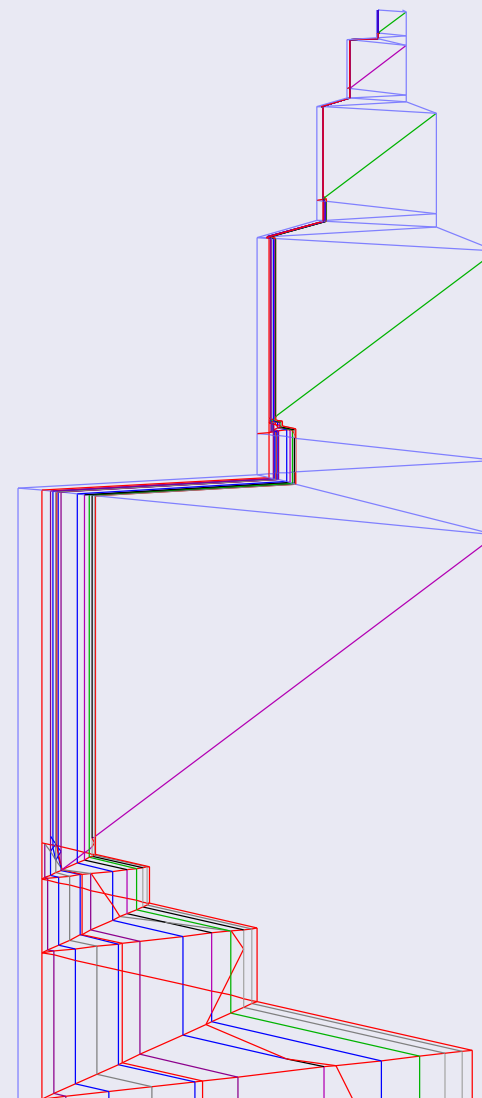

# Rational signal machines and isolated accumulations

## $\mathbb{Q}$ signal machine

- all speed are in  $\mathbb{Q}$
- all initial positions are in  $\mathbb{Q}$
- $\Rightarrow$  all location remains in  $\mathbb{Q}$

## Space and time location

- Easy to compute
- Not so easy to guess

## Forecasting any accumulation

Highly undecidable

( $\Sigma_2^0$  in the arithmetic hierarchy)

[Durand-Lose, 2006]

## Accumulation?

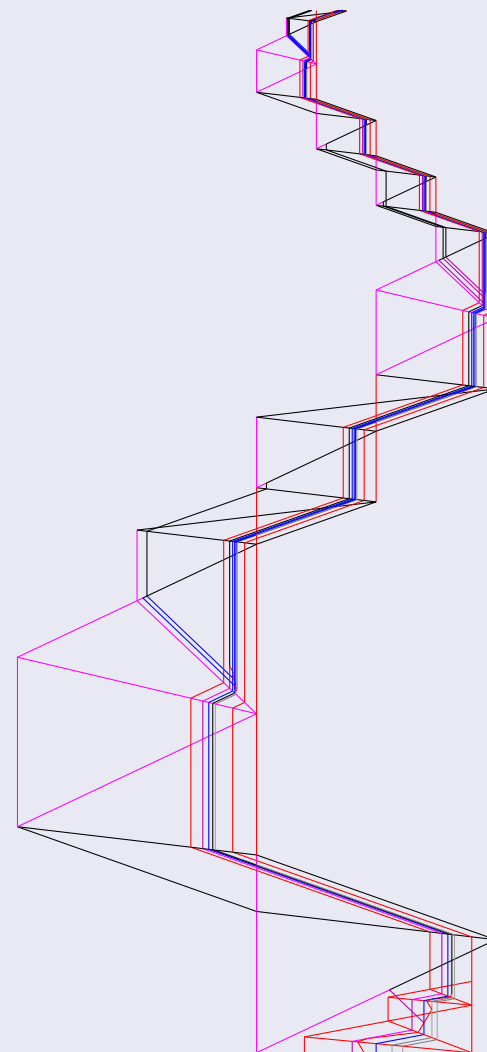

- 1 Signal machines and isolated accumulations
- 2 Necessary conditions on the coordinates of isolated accumulations
- 3 Manipulating *c.e.* and *d-c.e.* real numbers
- 4 Accumulating at *c.e.* and *d-c.e.* real numbers
- 5 Conclusion

## Temporal coordinate

### $\mathbb{Q}$ -signal machine

- $\mathbb{Q}$  on computers/Turing machine
  - exact representation
  - exact operations
- exact computations by TM (and implanted in Java)

### Simulation near an isolated accumulation

- on each collision, print the date
- $\rightsquigarrow$  increasing computable sequence of rational numbers (converges iff there is an accumulation)



## Spacial coordinate

### Static deformation by adding a constant to each speed

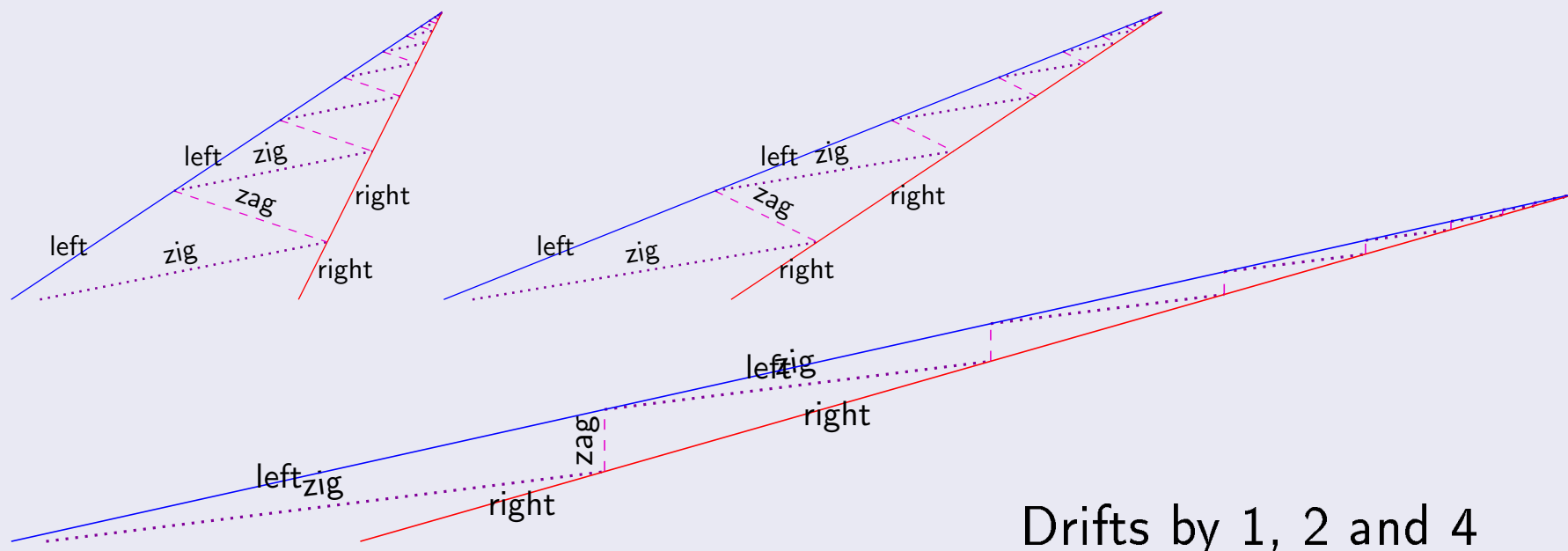

### With all speeds positive

- the left most coordinate is increasing (and computable) converges iff there is an accumulation
- correction by subtracting the date times the drift

### c.e. real number

- limit of a convergent increasing computable sequence of rational numbers
- no bound on the convergence rate
- represents a c.e. set (of natural numbers)
- stable by positive integer multiplication but not by subtraction

### d-c.e. real number

- difference of two c.e. real number
- form a field
- [Ambos-Spies et al., 2000]  
these are exactly the limits of a computable sequence of rational numbers that converges *weakly effectively*, i.e.,

$$\sum_{n \in \mathbb{N}} |x_{n+1} - x_n| \text{ converges}$$

- 1 Signal machines and isolated accumulations
- 2 Necessary conditions on the coordinates of isolated accumulations
- 3 Manipulating *c.e.* and *d-c.e.* real numbers**
- 4 Accumulating at *c.e.* and *d-c.e.* real numbers
- 5 Conclusion

# Encoding

For *d-c.e.* real numbers

$$x = \sum_{i \in \mathbb{N}} \frac{z_i}{2^i}, z_i \in \mathbb{Z}$$

the sequence  $i \rightarrow z_i$  is computable and

$$\sum_{i \in \mathbb{N}} \left| \frac{z_i}{2^i} \right| \text{ converges}$$

For *c.e.* real numbers

- identical but  $z_i \in \mathbb{N}$
- $z_i$  in signed unary representation

# TM outputting the infinite sequence

## Run

wait between

each  $z_i$

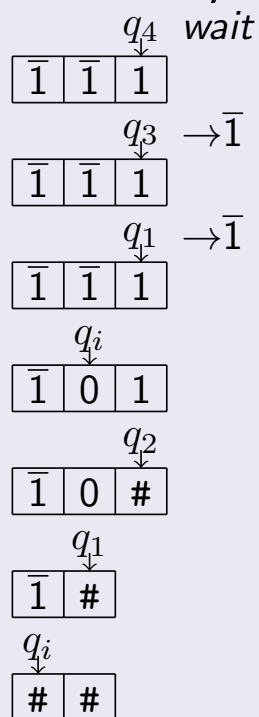

## Simulation

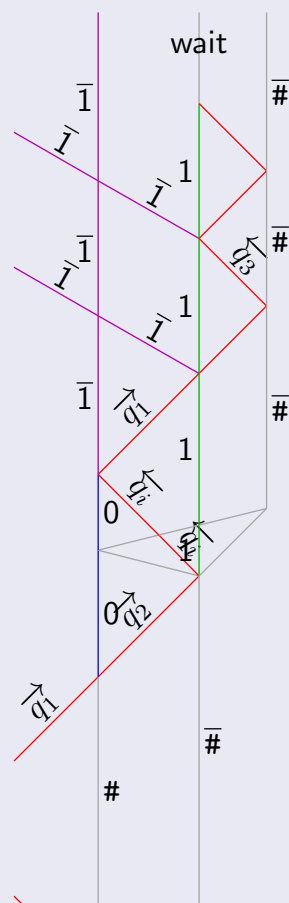

## Shrunk to output in bounded time

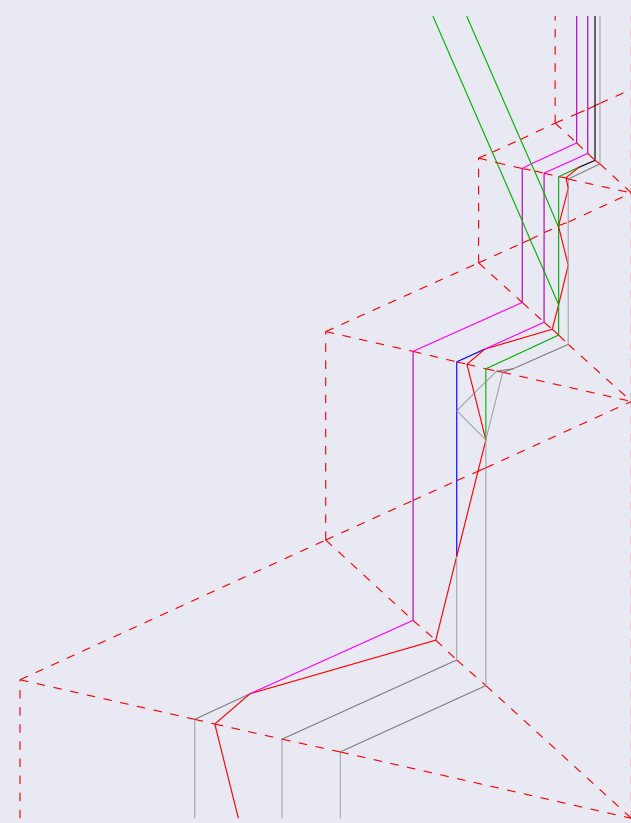

Simulation and shrinking structure stop after each value

- 1 Signal machines and isolated accumulations
- 2 Necessary conditions on the coordinates of isolated accumulations
- 3 Manipulating *c.e.* and *d-c.e.* real numbers
- 4 Accumulating at *c.e.* and *d-c.e.* real numbers**
- 5 Conclusion

## Two-level scheme

### Control/inner structure

- Provide the data for accumulating

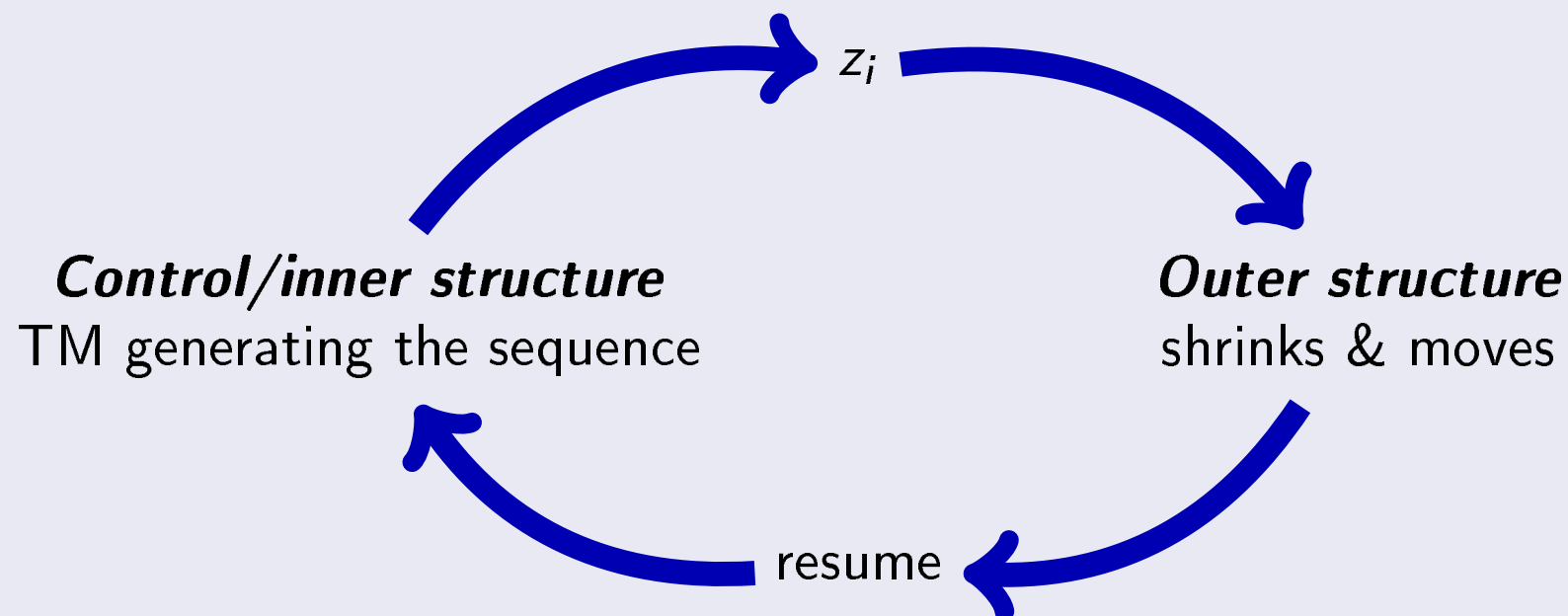

### Outer structure

- shrink and move the whole structure  $\rightsquigarrow$  accumulation

# Temporal coordinate

Wait the corresponding time

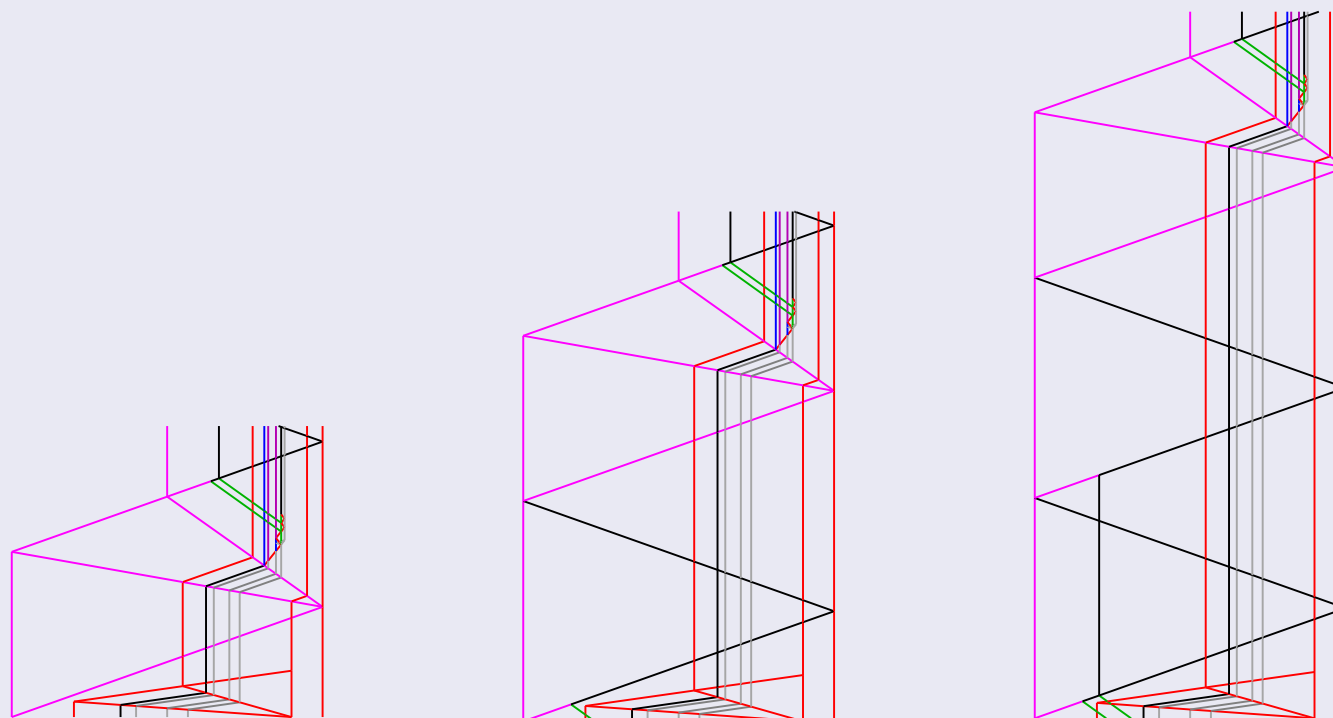

- Constant (up to scale) delay before outer structure action
- total delay is rational and should be previously subtracted



# Spatial coordinate

Move left or right, more or less

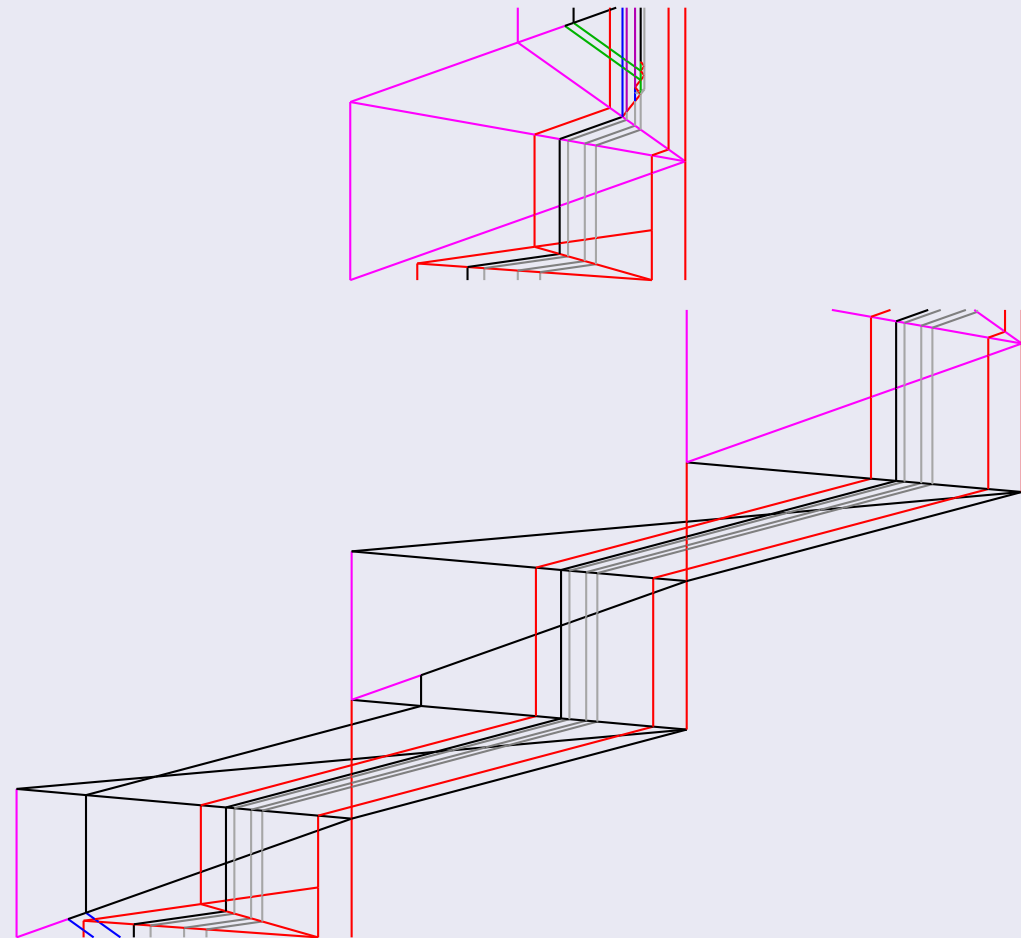
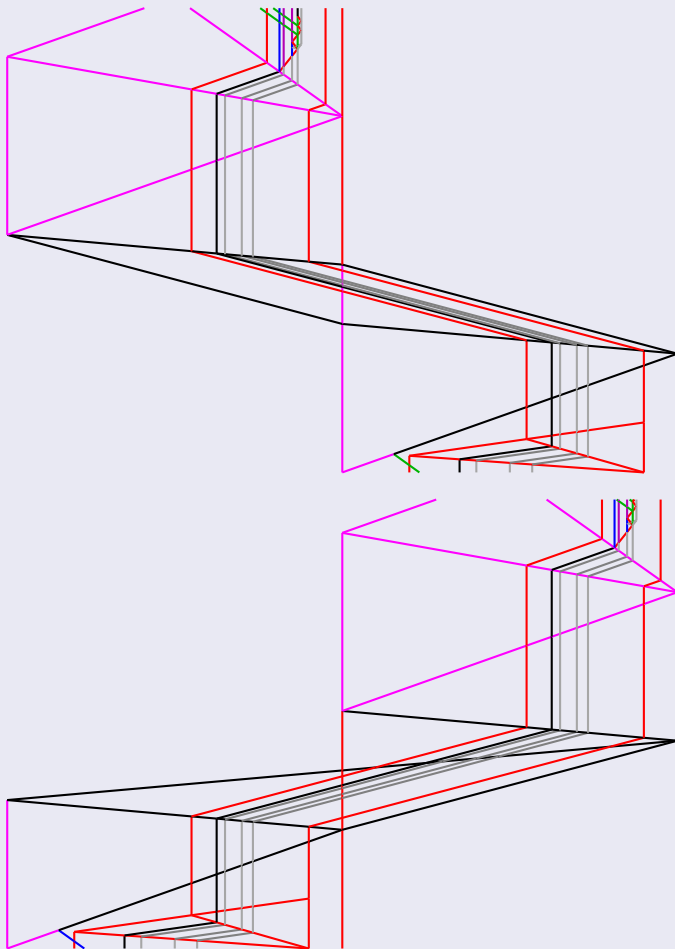

# Examples

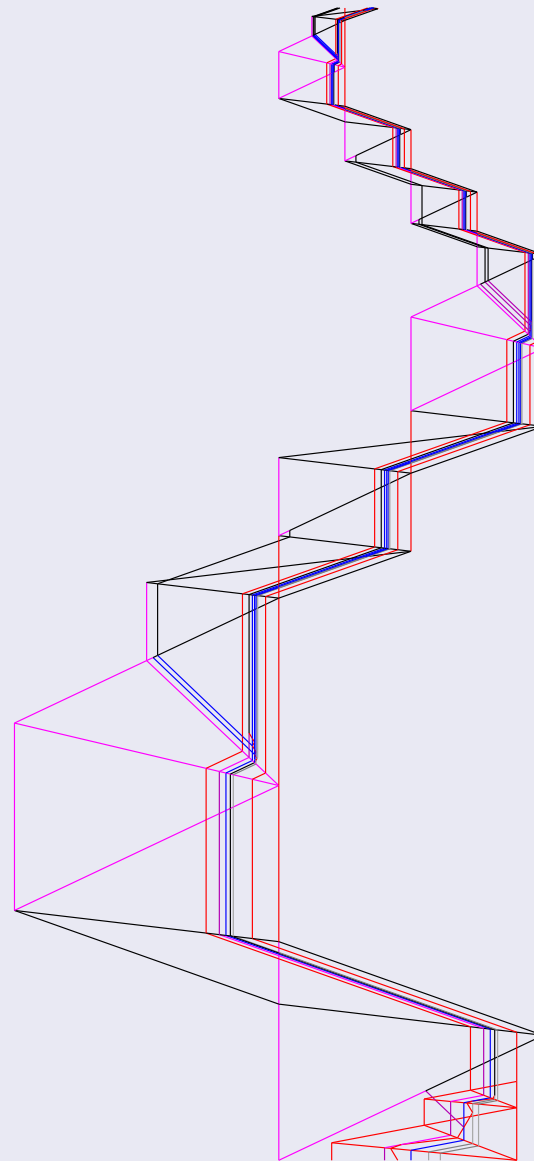
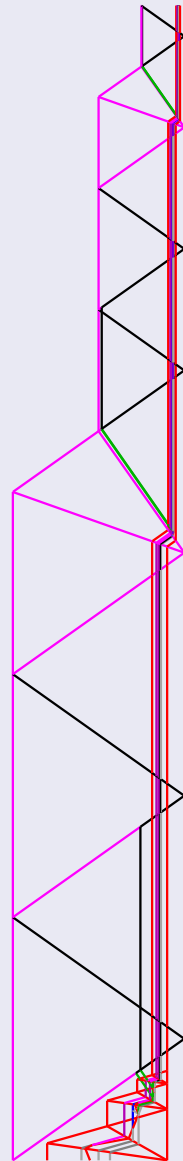

- 1 Signal machines and isolated accumulations
- 2 Necessary conditions on the coordinates of isolated accumulations
- 3 Manipulating *c.e.* and *d-c.e.* real numbers
- 4 Accumulating at *c.e.* and *d-c.e.* real numbers
- 5 Conclusion

## Results

- Isolated accumulations happen at  $d$ -c.e. spacial and c.e. temporal coordinates
- Accumulation at any c.e. temporal coordinate is possible
- Accumulation at any  $d$ -c.e. spacial coordinate is possible

## Perspectives

- Uncorrelate space and time coordinate  
it is possible for *computable* coordinates [Durand-Lose, 2010b]
- Higher order isolated accumulations
- Non isolated accumulations



Ambos-Spies, K., Weihrauch, K., and Zheng, X. (2000).

Weakly computable real numbers.

*J. Complexity*, 16(4):676–690.



Blum, L., Shub, M., and Smale, S. (1989).

On a theory of computation and complexity over the real numbers:  
NP-completeness, recursive functions and universal machines.

*Bull. Amer. Math. Soc.*, 21(1):1–46.



Durand-Lose, J. (2006).

Forecasting black holes in abstract geometrical computation is highly  
unpredictable.

In Cai, J.-Y., Cooper, S. B., and Li, A., editors, *Theory and  
Applications of Models of Computations (TAMC '06)*, number 3959  
in LNCS, pages 644–653. Springer.



Durand-Lose, J. (2008).

Abstract geometrical computation with accumulations: Beyond the  
Blum, Shub and Smale model.

In Beckmann, A., Dimitracopoulos, C., and Löwe, B., editors, *Logic and Theory of Algorithms, 4th Conf. Computability in Europe (CiE '08) (abstracts and extended abstracts of unpublished papers)*, pages 107–116. University of Athens.



Durand-Lose, J. (2009).

Abstract geometrical computation 3: Black holes for classical and analog computing.

*Nat. Comput.*, 8(3):455–472.



Durand-Lose, J. (2010a).

Abstract geometrical computation 5: embedding computable analysis.

*Nat. Comput.*

Special issue on Unconv. Comp. '09.



Durand-Lose, J. (2010b).

The coordinates of isolated accumulations [includes] computable real numbers.

In Ferreira, F., Guerra, H., Mayordomo, E., and Rasga, J., editors, *Programs, Proofs, Processes, 6th Int. Conf. Computability in Europe (CiE '10) (abstracts and extended abstracts of unpublished papers)*, pages 158–167. CMATI, U. Azores.



Durand-Lose, J. (2011).

Abstract geometrical computation 4: small Turing universal signal machines.

*Theoret. Comp. Sci.*, 412:57–67.



Weihrauch, K. (2000).

*Introduction to computable analysis.*

Texts in Theoretical computer science. Springer, Berlin.